



IncOder CORE Series Datasheet

IncOder Product Guides

Document Revision: 7
Exported on: 11/03/2023

Celera Motion, A Novanta Company
125 Middlesex Turnpike,
Bedford, MA 01730, USA

www.celeramotion.com

Table of Contents

1	General Information	4
1.1	Revision History	4
1.2	Disclaimers and limitations of liability	4
2	Overview	5
2.1	Features and Benefits	6
3	Specifications	7
4	Storage and Handling.....	11
4.1	Handling Considerations	11
4.2	Storage Considerations	11
4.3	Electrical Safety.....	11
5	Electrical Interface.....	12
5.1	Connector Overview	12
6	Mechanical Dimensions	14
6.1	Mechanical Mounting Format.....	14
6.1.1	Screw Mount Stator & Screw Mount Rotor - Product Option CORE-1	14
6.2	Connection Options	15
7	Installation	17
7.1	Mounting Features.....	17
7.2	Alignment Tolerances.....	17
7.3	Metal Exclusion Zone.....	17
7.4	Metal Exclusion Zone Example - CORE-3-70-XX1001-XXXX-PR1.....	19
7.5	Zero Position and Zero Setting	21
8	Communications	22
8.1	BiSS-C (unidirectional) Protocol	22
8.1.1	BiSS-C (unidirectional) - Product Option BIS3	22

8.1.2	Data Area Definition	23
8.1.3	Example for 18 bits resolution:.....	24
8.2	SSI - Synchronous Serial Interface Protocol.....	24
8.2.1	SSI - Product Options SSI1 to SSI9.....	25
8.3	Asynchronous Serial Interface	30
8.3.1	Asynchronous Serial Interface - Product Options ASI1, ASI2	30
8.4	Serial Peripheral Interface.....	32
8.4.1	Serial Peripheral Interface (SPI) - Product Option SPI1.....	32
8.4.2	SPI1 Timing Information.....	34
9	How to Order	37
9.1	IncOder CORE Part Numbers.....	37
10	Cable Information	40
10.1	Cable Part Number.....	40
10.2	Cable Drawing.....	40
10.3	Cable Wire Assignment.....	41
11	Warranty / Remedy	43



1 General Information

1.1 Revision History

Revision	Release Date	Changes
1.0	Sep 29 2021	Initial Release
1.1	Jul 4 2022	Replaced connector images - PR1 installation image
1.2	October 6 2023	70mm size added
1.2.1	November 3 2023	Document style updates

1.2 Disclaimers and limitations of liability

The information contained within this document contains proprietary information belonging to Celera Motion. Such information is supplied solely for the purpose of assisting users of the product in its installation.

Celera Motion rejects all liability for errors or omissions in the information or the product or in other documents mentioned in this document.

The text and graphics included in this document are for the purpose of illustration and reference only. The specifications on which they are based are subject to change without notice.

This document may contain technical or other types of inaccuracies. The information contained within this document is subject to change without notice and should not be construed as a commitment by Celera Motion. Celera Motion assumes no responsibility for any errors that may appear in this document.

Some countries do not allow the limitation or exclusion of liability for accidental or consequential damages, meaning that the limits or exclusions stated above may not be valid in some cases.



2 Overview

IncOder CORE is a lightweight absolute rotary encoder series, fully-contained in an open frame printed circuit board kit. The frameless, compact design reduces system weight and design envelope, making it suited for integration into robotic joints and motorized actuators. The angle feedback sensor utilizes a unique, field-proven inductive technique, that delivers repeatable, accurate and high resolution absolute digital feedback. IncOder CORE is insensitive to contamination, delivering robust angle measurement performance.

The angle sensor can be installed quickly and simply, by mounting the rotor and stator pair into the host assembly by means of M2 screw mounting holes. With modest installation tolerances, a programmable zero set and no calibration required, the sensor can simply be screwed and doweled in place for fast and practical setup.

Each sensor includes a passive rotor target, paired with an active stator. The stator contains all the required processing electronics in a lightweight, stacked circuit board package. The stator features a 10-way Molex PicoClasp connector for power input and data output. The IncOder CORE sensor can be configured with an axial or radial connector for optimised system design.

IncOder CORE is available in 44mm and 70mm O.D. sizes and can be configured during build to output up to 20-bits of absolute digital position data in a range of protocol options including SPI, BiSS-C, and SSI.





2.1 Features and Benefits

- Frameless, compact design for reduced weight and design envelope
- Repeatable, Accurate and High Resolution absolute position feedback
- Large bore and low axial height for use in rotary actuators
- Insensitive to contamination, providing robust position measurement
- No precision installation tolerances, providing simple installation
- No calibration, reducing OEM production time and cost
- Economical price for reduced system cost
- Customization and additional sizes for optimized system design



3 Specifications

System Data	44mm	70mm
Measurement	Absolute over 360 °	
Resolution	10-17 bits	10-20 bits
Accuracy	±360”	±125”
Installation Gap	0.5 ± 0.2 mm	1.1 ± 0.35 mm
Max Radial Offset	0.2 mm	0.25 mm
Max. Physical Speed	10,000 rpm	
Repeatability (within a single power cycle)	±1 LSB	
Measurement Update Rate	10 kHz	
Internal Position Update Period	100 μs	
Thermal Drift Co-efficient	<1 ppm	
Electrical Data	44mm	70mm
Supply Voltage	4.5 - 5.5 VDC, 8 - 12 VDC	
Current Consumption	<100 mA (typically <75 mA and does not change significantly with voltage supply)	



Electrical Data	44mm	70mm
Data I/O	RS422 Compatible, supports SSI, SPI, BiSS-C or ASI (asynchronous serial interface)	
Reverse Polarity Protection	PSU Reverse polarity protected to 32 VDC	
Power Up Time to 1st Measurement	<120 ms	
BiSS Max. Clock Rate	2.5 MHz	
SPI Max. Clock Rate	4 MHz	
SSI Max. Clock Rate	2 MHz	
Zero Setting	Zero Set / Zero Reset via Connector Pin	
Mechanical Data	44mm	70mm
Rotor OD	ø35.6 mm	ø65 mm
Rotor Screw Hole PCD	ø36 mm	ø36.6 mm
Stator OD	ø44 mm	ø68.8 mm
Stator Screw Hole PCD	ø56.8 mm	ø75.0 mm
ID	ø10.4 mm	ø30.3 mm
Total Height (Clearance)	12.1 mm	13.4 mm



Mechanical Data	44mm	70mm
Mass (Rotor, Stator, Total)	3 g, 12 g, 15 g (not including mounting hardware)	6.5g, 22.5g, 29g (not including mounting hardware)
CORE-1 Mounting	External Screw Mount Rotor, External Screw Mount Stator M2 screw mount. Fix rotor using c.sunk screws, stator using cap screws	N/A
CORE-3 Mounting	N/A	Internal Screw Mount Rotor, External Screw Mount Stator M2 screw mount. Fix rotor using c.sunk screws, stator using cap screws
Connector	10-way Molex PicoClasp	
Environmental Data	44mm	70mm
IP Rating	IP00 (options for conformal coating available)	
Operating Temperature	-20 °C to 85 °C	
Storage Temperature	-40 °C to 105 °C	
Contamination Immunity	Tolerant to dust, dirt, oily fingerprints.	
Humidity	10-85 % RH Non-Condensing	



User Cable Data	44mm	70mm
Terminations	End A: Molex 10-way connector End B: Coated wires, stripped 1mm (max 1.3mm).	
Standards	BS 3G 210	
Wire Gauge	28 - 32 AWG	
Wire Coating	PTFE coated	
Sleeve	Polychloroprene sections	
Length Tolerance	± 5 %	



4 Storage and Handling

IncOder CORE is a precision encoder and has been designed to function in a wide range of applications and environments. To take full advantage of the encoder design, allow easy access to the sensor for service and/or replacement. For optimal performance and reliability:

- DO follow standard ESD precautions while handling the sensor.
- DO allow proper clearance for stator-rotor alignment.
- DO follow setup and alignment instructions for the encoder system.
- DO NOT store sensors in an uncontrolled environment.
- DO NOT electrically overstress the sensor (power supply ripple/noise).
- DO NOT intentionally “hot swap” the sensor if the device is energized.

4.1 Handling Considerations

- Follow standard Electrostatic Discharge (ESD) precautions at all times.
- We advise correct use of earthed antistatic mats, earth straps and wrist straps when handling the device components.
- Gloved handling is not required but is recommended. If gloves are not used, hands should be clean.

4.2 Storage Considerations

When storing, only anti-static or static shielded packaging and storage media are advised to be used as primary or secondary packaging for the product.

4.3 Electrical Safety

To protect the encoder, and for compliance with EMC, it is recommended to install the encoder in an enclosed metal housing.

Further considerations from the end system manufacturer are required if other signals and sources of interference will pass through the housing.

Typical sources of electrical interference include the following: strong magnetic fields from transformers, brakes, and electric motors, relays, contactors, and solenoid valves, high-frequency equipment, pulse devices, and stray magnetic fields from switching power supplies, power cables and supply lines to the above mentioned devices.

Measures the user can take to mitigate interference during operation are:

- Properly install or mount encoders in accordance with the mounting instructions.
- Do not install cables in the immediate vicinity of interference sources.
- Ensure the metal shield does not leak, and that it is suitably grounded.



5 Electrical Interface

5.1 Connector Overview

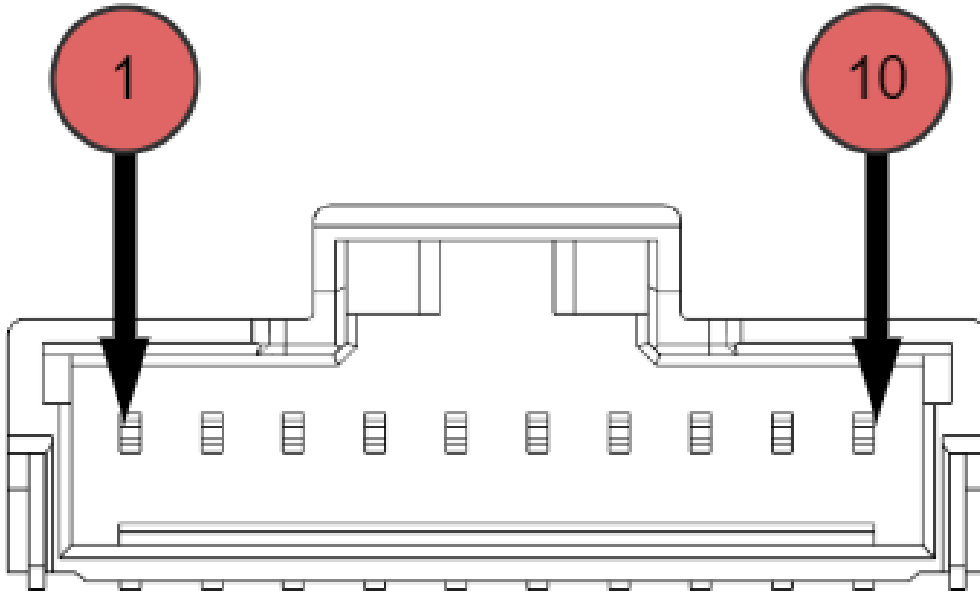

IncOder CORE Connector		
Molex 10-way PicoClasp Connector		
Pin	Signal	Function
1	Zero Set	Optional Zero Set function. To use, connect to electrical ground (<0.5V) for >3 seconds at power up but left unconnected (i.e. open circuit) during operation.
2	Zero Reset	Optional Zero Reset function. To use, connect to electrical ground (<0.5V) for >3 seconds at power up but left unconnected (i.e. open circuit) during operation.
3	Reserved	Reserved for future use.
4	Reserved	Reserved for future use.



5	DATA A	Absolute Encoder Output (Data A / Data +)
6	CLOCK A	Clock Input (Clock A / Clock +)
7	DATA B	Absolute Encoder Output (Data B / Data -)
8	CLOCK B	Clock Input (Clock B / Clock -)
9	0V	Digital signal ground.
10	V _{supply}	Supply 4.5-5.5V, 8-12V, <100mA



6 Mechanical Dimensions

6.1 Mechanical Mounting Format

6.1.1 Screw Mount Stator & Screw Mount Rotor - Product Option CORE-1

44mm Mechanical Drawings

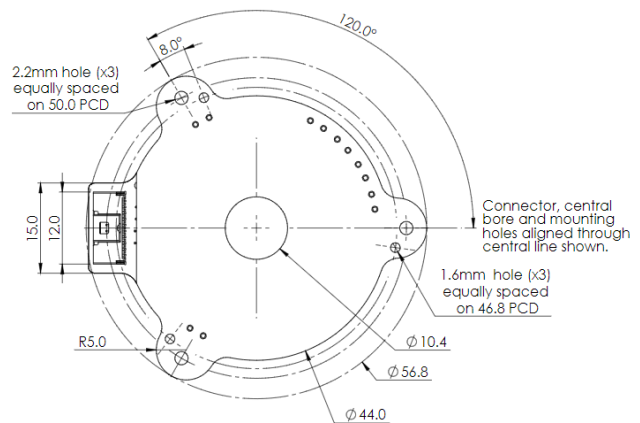
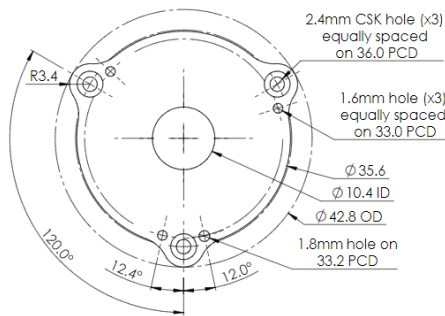
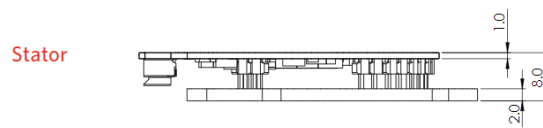
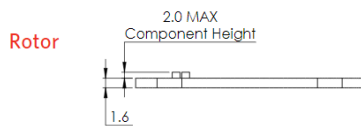

1 Note: Radial Connection Type 2 - Product Option PR2



70mm Mechanical Drawings

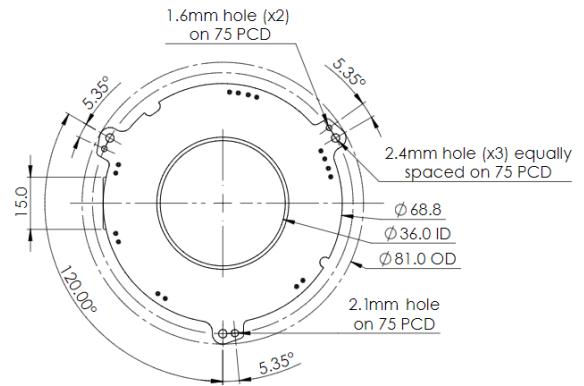
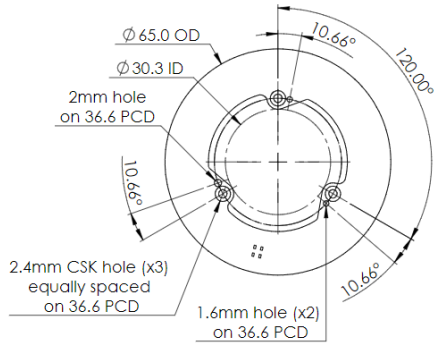
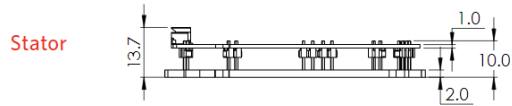
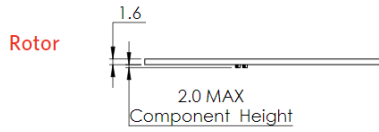

Drawing Tol = ± 0.2 mm

2 Note: Radial Connection Type 1 - Product Option PR1

6.2 Connection Options

Radial Connection Type 1

-

Product Option PR1

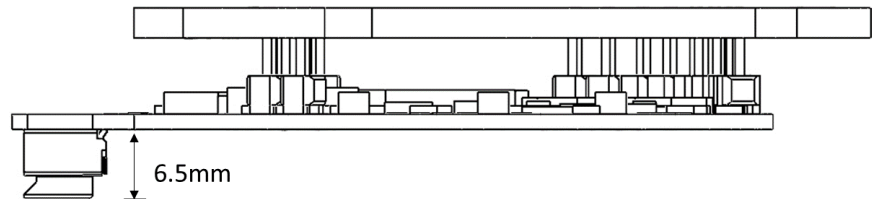



Radial Connection Type 2

-

Product Option PR2

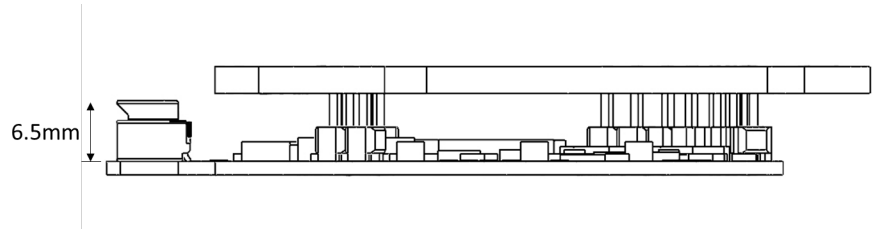

Axial Connection Type 1 -

Product Option PA1

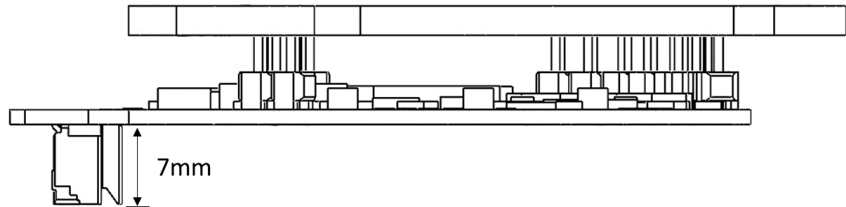



7 Installation

IncOder CORE is an unpackaged encoder requiring the user to design mounting features for integration of the position sensor within the host system assembly, taking into consideration alignment tolerances, mounting features, shielding and metal exclusion volume.

7.1 Mounting Features

IncOder CORE consists of an active stator and passive rotor. Both component parts contain mounting features as outlined in Mechanical Dimensions, which includes screw mounting holes and alignment dowel holes. Recommended installation is to align and locate both the rotor and stator using the dowel features in the rotor and stator, and screw in place using the M2 screw holes provided. The rotor features countersunk screw holes, and an additional dowel hole for locating Zero Position. The stator features clearance screw holes for mounting with cap screws.

Note: It is recommended to mount the IncOder using non-metal spacers to ensure the Metal Exclusion Zone is established. See Metal Exclusion Zone section for details.

7.2 Alignment Tolerances

IncOder CORE consists of a rotor-stator pair. The rotor and stator should be mounted within the prescribed mounting tolerances. Provided axial gap and non-concentricity tolerances are maintained, then the stated measurement performance will be met.

Installation Tolerances	44mm	70mm
Gap	0.5 ± 0.2 mm	1.1 ± 0.35 mm
Non-concentricity	± 0.2 mm	± 0.2 mm

7.3 Metal Exclusion Zone

The rotor and stator should be mounted within the prescribed mounting tolerances while also taking into consideration the Metal Exclusion Zone, which defines the volume around the encoder where metal should not enter.

Other than the central host shaft; rotor mounting screws; and dowels, electrically conductive or magnetically permeable objects **should not** be located within 3mm of the rotor faces during operation. This metal exclusion zone could be established by designing and mounting the encoder with non-metal spacers as shown (not included). For specific guidance on incorporating IncOder



CORE into your mechanical assembly, including where metal will be present within the exclusion zone, please contact Celera Motion.

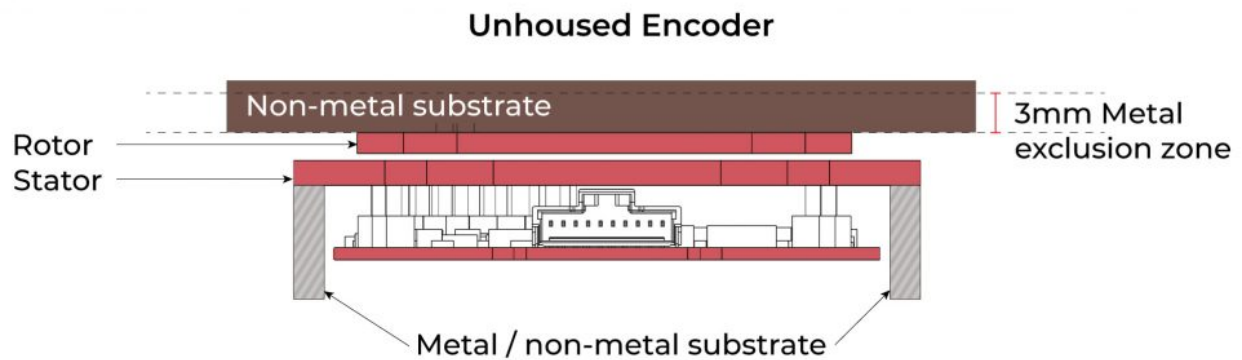
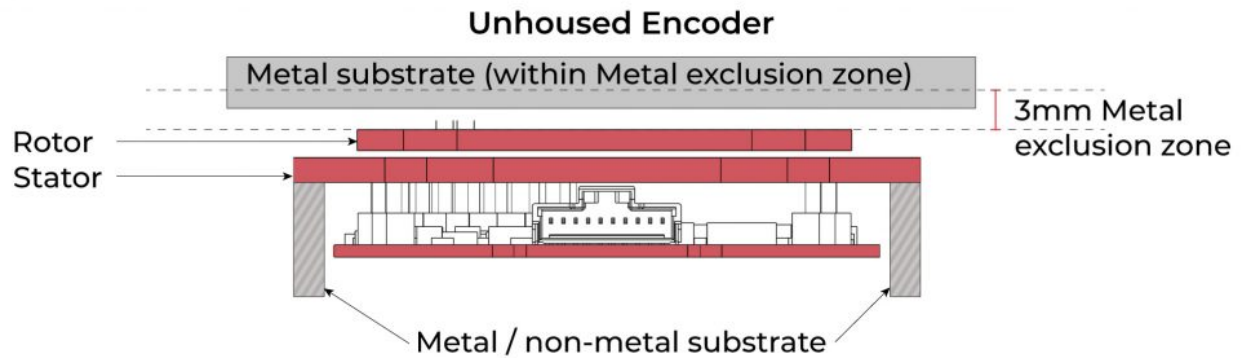

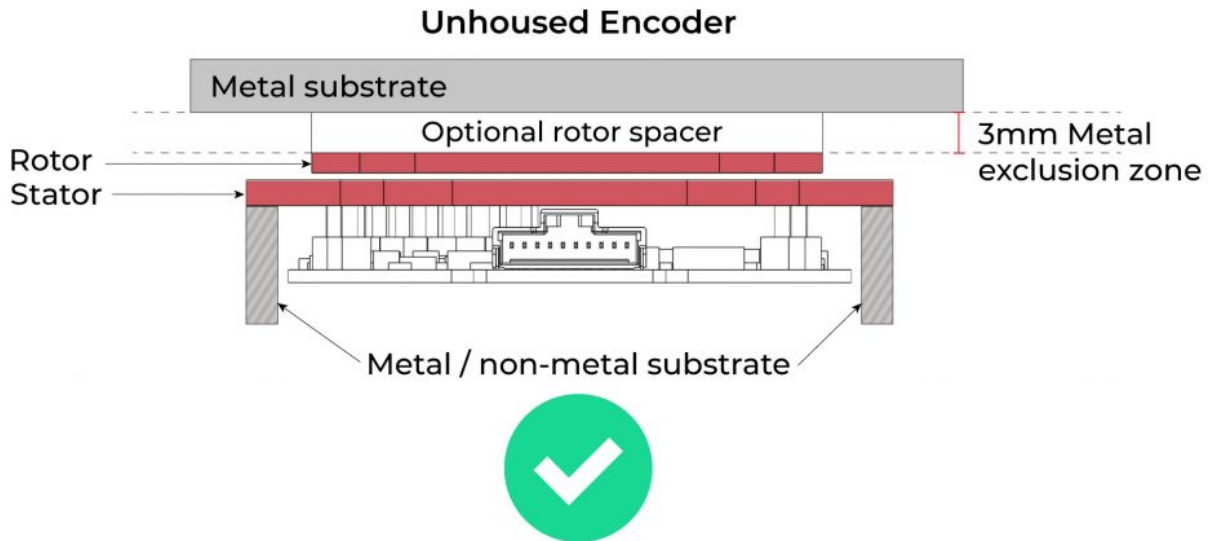

Notes:

- Failure to follow the prescribed guidance may result in a degradation of measurement performance.
- Do not route the connection cable within and between the stator-electronic PCB stack.
- Ensure isolation of the stator e-board to host mechanics.

7.4 Metal Exclusion Zone Example - CORE-3-70-XX1001-XXXX-PR1

The following representation displays the Metal Exclusion Zone for the IncOder CORE - 70mm variant. The green region specifies the metal exclusion zone. The rotor has been fitted with an example of a non-metal spacer.

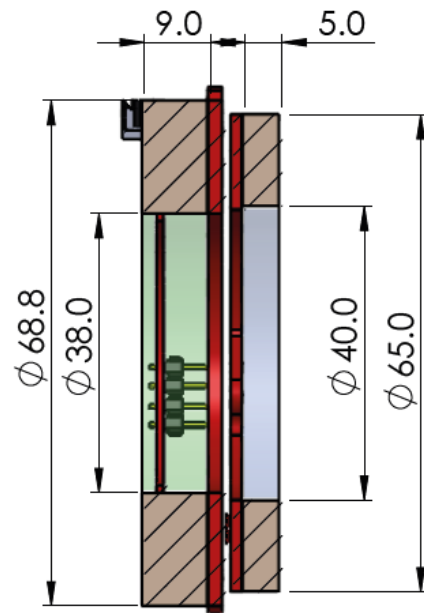
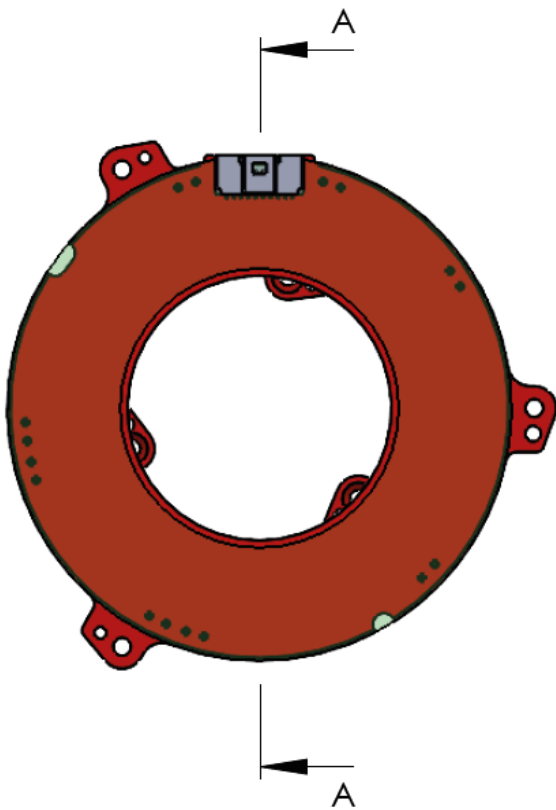
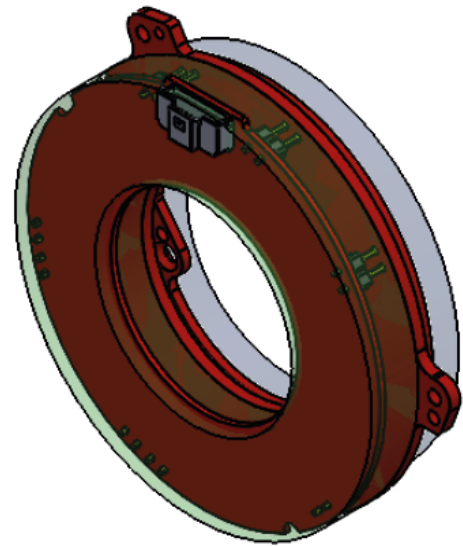
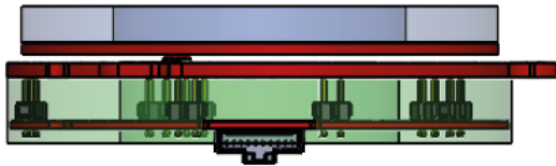

SECTION A-A



7.5 Zero Position and Zero Setting

The Zero Point is the datum from which angle is measured. As supplied, the IncOder CORE carries a factory Zero Point setting. The zero point is within $\pm 5^\circ$ of the "O" within the screen printed "IncOder" logo on the rotor, aligned with the same respective feature on the stator.

The Zero Point can be changed using the Zero Set and Zero Reset lines on the electrical interface. The Zero Set signal will set the current position as the Zero Point (held in memory when power is removed). Zero Reset signal will reset the Zero Point to the factory setting (held in memory when power is removed). To use, the relevant connection should be connected to electrical ground ($<0.5V$) for 3 seconds at power up but left unconnected (i.e. open circuit) during operation.



8 Communications

Notes:

- All digital communications interfaces conform to the RS422 standard.
- DATA & CLOCK inputs are not terminated with load resistors.

8.1 BiSS-C (unidirectional) Protocol

BiSS-C is a popular communications interface between controllers and position sensors. The IncOder BiSS-C interface is unidirectional and provides fast, compact, economic serial communications using RS422 (SSI) compatible hardware. The IncOder BiSS-C interface is a point to point configuration (a single device with a single slave), conforming to the requirements of BiSS-C Unidirectional. In this configuration, the IncOder is the only slave connected to the master (the host control system).

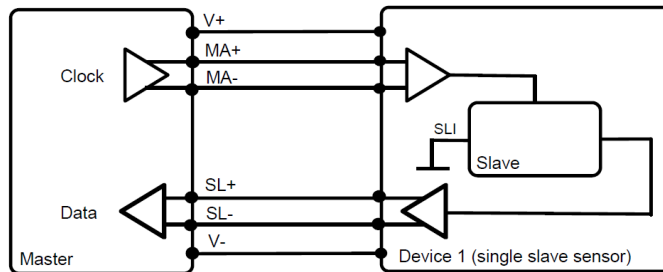

The Master transmits clock signals to the Slave via the MA line. The SL line carries the sensor data directly from the Slave back to the Master. The interface has only two unidirectional, differential lines (as the IncOder permanently connects the input SLI to '0'). Parameters for the individual data channels are specified below. These parameters can be pre-programmed in the controller and referenced via an ID or lookup table, or manually entered.

The IncOder implements a “pipelined” data output. The position (and status) returned in the SCD is from the position measurement triggered by the previous BiSS frame (provided that the frame repetition period is between 95Qs and 140Qs, as is described for the SPI1 protocol (see SPI Timing Information)).

8.1.1 BiSS-C (unidirectional) - Product Option BIS3

BIS3 Protocol Timing Parameters				
Symbol	Parameter	Min.	Max.	Unit



BIS3 Protocol Timing Parameters				
$1/T_{MA}$	Clock Frequency	600	2000	kHz
$T_{BISS-TIMEOUT}$	BiSS Timeout	15	20	μ s

BIS3 Protocol Data Channel Parameters	
Number of Bits (SCD Length)	30 bits
Processing Time	12 Clock Cycles ($12 \times T_{MA} \mu$ s)
Data Area Length & Alignment	24 bits
CRC (Cyclic Redundancy Check)	Width: 6 Bits Polynomial: 0x43 Initial Value: 0x00 Output Inverted

8.1.2 Data Area Definition

MSB	LSB										
D[r+11]	D[r+10]	...	D[r+1]	D _r	D[r-1]	...	D ₂	D ₁	D ₀	nE	nW

BIS3 Protocol Data Definition	
Symbol	Description
D21	Most significant bit of the position data (if IncOder resolution is <22 bits, the LSBs are set to '0').



D0	Least significant bit of the position data.
nE	'1' = position valid
nW	Always '1'

8.1.3 Example for 18 bits resolution:

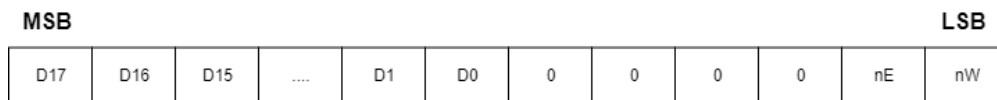

Note: For details regarding BIS1 and BIS2 legacy variants, please contact Celer Motion.

8.2 SSI - Synchronous Serial Interface Protocol

SSI is a widely used serial interface between position sensors and controllers. It is based on the RS-422 hardware standard and implements a differential output for the DATA and a differential input for the CLOCK. (Note that DATA outputs and CLOCK inputs are not terminated with load resistors.)

Synchronous SSI uses a clock sequence from a controller to initiate the transmission of position data from the sensor (a Read Cycle), with the latest position data (see Specifications for internal position update rate) available for transmission after each SSI Read Cycle is completed. See timing information below:-

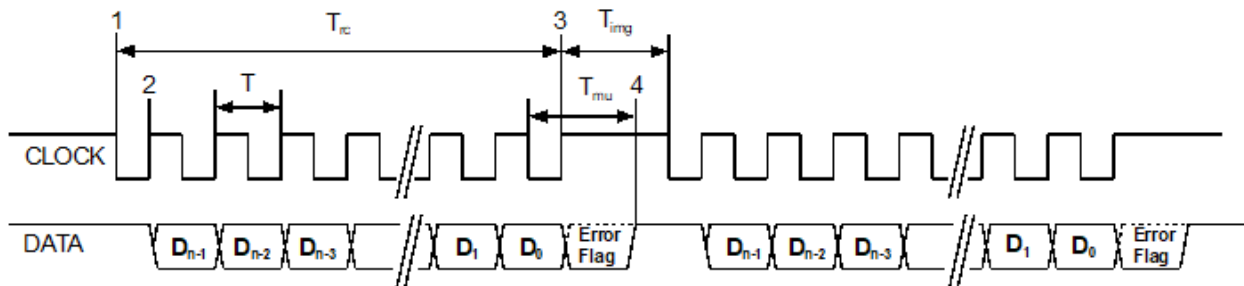

3 SSI Timing Information

SSI Timing Parameters		
Symbol	Parameter	Description



T	Clock Period	$1/T = 100 \text{ kHz to } 2 \text{ MHz}$
T_{rc}	Read Cycle Time	Defined as $(n \times T) + (0.5 \times T)$
T_{mu}	Message Update Time	The time from last falling edge of clock to when new data is ready for transmission. $T_{mu} = 20\mu\text{s} \pm 1\mu\text{s}$. The DATA line will be HIGH after this time indicating a new Read Cycle can be started.
T_{img}	Inter-message Gap Time	Must be $> T_{mu}$ otherwise position data will be indeterminate.
n	Number of Bits	The number of bits in the message (not including the Error Flag). In idle state CLOCK and DATA are both HIGH.

Notes

1. The first falling edge after T_{mu} starts the Read Cycle and the transfer of data.
2. Each rising edge of the CLOCK transmits the next data bit of the message, starting with Dn-1.
3. After the last rising edge of the clock sequence, the data line is set by the Error Flag (if supported) for period $T_{mu} - 0.5 \times T$
4. After T_{mu} , the latest position data is now available for transmission in the next Read Cycle - see Section 5.12 for position update rate.

IncOders can support a variety of SSI protocol types in which data is transmitted depending on the requirements of the SSI controller. IncOder can be supplied with any of the following protocols - just choose what you need by selecting the relevant Product Option when ordering. If the protocol you require is not listed here then please consult Celera Motion or your local representative.

8.2.1 SSI - Product Options SSI1 to SSI9

SSI1 Protocol Data Definition (n = 24)			
Bit	Symbol	Definition	Description
D23	PV	Position Valid Flag	Set to 1 when data is valid, otherwise 0 (the inverse of the ERROR FLAG).



SSI1 Protocol Data Definition (n = 24)			
D22	ZPD	Zero Position Default Flag	Set to 1 when the Zero Point is at Factory Default, otherwise 0.
D21 - D0	PD[21:0]	Binary Position Data	Binary position data. If resolution of device is less than 22 bits, then the MSBs of this field are set to 0. The LSB of this field is in D0. When PV is 0, PD[21:0] value is not defined.

SSI2 Protocol Data Definition (n = 24)			
Bit	Symbol	Definition	Description
D23-D2	PD[21:0]	Position Valid Flag	Binary position data. If resolution of device is less than 22 bits, then the MSBs of this field are set to 0. The LSB of this field is in D2. When Alarm bit is 1, PD[21:0] value is not defined.
D1	P	Parity Bit	0 indicates an even number of 1's in data (D23-D2), 1 indicates an odd number of 1's in data.
D0	A	Alarm Bit	0 indicates normal operation, 1 indicates error condition.

SSI3 Protocol Data Definition (n = 16)			
Bit	Symbol	Definition	Description



SSI3 Protocol Data Definition (n = 16)

D15-D0	PD[15:0]	Binary Position Data	<p>Binary position data. When error flag is 1, PD[15:0] value is not defined.</p> <p>Note: The use of SSI3 limits the measurement resolution to a maximum of 16 bits.</p>
--------	----------	----------------------	---

SSI4 Protocol Data Definition (n = 32)

Bit	Symbol	Definition	Description
D31	PV	Position Valid Flag	Set to 1 when position data valid, otherwise 0 (inverse of ERROR FLAG).
D30	ZPD	Zero Position Default Flag	Set to 1 when the Zero Point is at Factory Default, otherwise 0.
D29-D11	PD[18,0]	Binary Position Data	If resolution of device is less than 19 bits, then the MSBs of this field are set to 0. The LSB of this field is in D11. When PV is 0, PD[18:0] value is not defined.
D10-D0	TS[10,0]	Time Stamp Data	<p>The value of the Time Stamp counter when the position was measured. This data is always valid.</p> <p>The Time Stamp counter is a continuously incrementing counter in the range: 0.00ms to 20.47ms (at which point it restarts at 0.00ms). It has a resolution of 10us, with an accuracy better than 1% (based on the system oscillator).</p> <p>Note: the use of SSI4 limits the measurement resolution to a maximum of 19 bits.</p>



SSI5 Protocol Data Definition (n = 16)			
Bit	Symbol	Definition	Description
D15-D0	PD[15:0]	Gray Code Position Data	<p>Gray Code Position Data. When error flag is 1, PD[15:0] value is not defined.</p> <p>Note: The use of SSI5 limits the measurement resolution to a maximum of 16 bits.</p>

SSI6 Protocol Data Definition (n = 32)			
Bit	Symbol	Definition	Description
D31-D24	CRC[7:0]	Cyclic Redundancy Check	<p>CRC-8: To verify transmission, calculate the CRC of the bottom 24 bits of the message. The resulting CRC should be the same as the received CRC field.</p> <p>The following parameters define CRC-8:</p> <p>Polynomial 0x97</p> <p>Initial data 0x00</p> <p>MSB First (not reversed)</p> <p>No final XOR calculation</p>
D23	PV	Position Valid Flag	Set to 1 when position data is valid, otherwise 0 (the inverse of the ERROR FLAG).
D22	ZPD	Zero Position Default Flag	Set to 1 when the Zero Point is at Factory Default, otherwise 0.
D21-D0	PD[21:0]	Binary Position Data	<p>Binary position data. If resolution of device is less than 22 bits, then the MSBs of this field are set to 0. The LSB of this field is in D0.</p> <p>When PV is 0, PD[21:0] value is not defined.</p>



SSI7 Protocol Data Definition (n = 30)			
Bit	Symbol	Definition	Description
D29-D24	-	'0'	Data always 0.
D23-D2	PD[21:0]	Binary Position Data	Binary position data. If resolution of device is less than 22 bits, then the MSBs of this field are set to 0. The LSB of this field is in D2. When Alarm bit is 1, PD[21:0] value is not defined.
D1	P	Parity Bit	0 indicates an even number of 1's in data (D23-D2) 1 indicates an odd number of 1's in data.
D0	A	Alarm Bit	0 indicates normal operation, 1 indicates error condition.

SSI8 Protocol Data Definition (n = 18)			
Bit	Symbol	Definition	Description
D17-D0	PD[17:0]	Gray Code Position Data	Gray code, position data. When ERROR FLAG is 1, PD[17:0] value is not defined. Note: the use of SSI8 limits the measurement resolution to a maximum of 18 bits.

SSI9 Protocol Data Definition (n = 32)			
Bit	Symbol	Definition	Description



SSI9 Protocol Data Definition (n = 32)			
D31	PV	Position Valid Flag	Set to 1 when position data valid, otherwise 0 (inverse of ERROR FLAG).
D30	ZPD	Zero Position Default Flag	Set to 1 when the Zero Point is at Factory Default, otherwise 0.
D29-D11	PD[18:0]	Binary Position Data	If resolution of device is <19 bits, then the MSBs of this field are set to 0. The LSB of this field is in D11. When PV is 0, PD[18:0] value is not defined.
D10-D0	TS[10:0]	Time Stamp Data	The value of the Time Stamp counter when the position was measured. This data is always valid. The Time Stamp counter is a continuously incrementing counter in the range: 0.00ms to 2.047ms (at which point it restarts at 0.00ms). It has a resolution of 1 μ s, with an accuracy better than 1% (based on the system oscillator).

8.3 Asynchronous Serial Interface

This section describes the communications interface for IncOders with ASI1 and ASI2 serial protocols. Data is transmitted by the IncOder continuously formatted into Frames. Each Frame consists of a number of 8 bit data words. Each 8 Bit data word (or byte) is transmitted from a standard UART using N-8-1 (no parity, 8 data bits, 1 stop bit). ASI1 has a Baud rate of 230400 and ASI2 has a Baud rate of 921600. See below for the data format of each transmitted data word. ASI1 Frames are transmitted at a rate of 3.33kHz nominal. ASI2 frames are transmitted at a rate of 10kHz nominal (same rate as Internal Position Update Period).

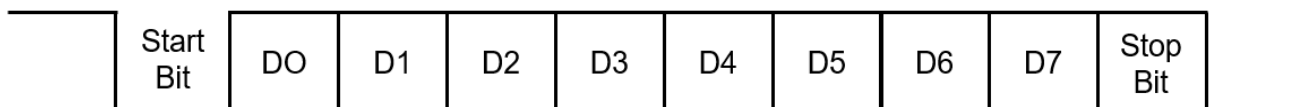

8.3.1 Asynchronous Serial Interface - Product Options ASI1, ASI2

The following is the Asynchronous Serial Data protocol specified with the ASI1 or ASI2 Product Option. Each frame is defined as 6 bytes and the data format is defined as follows:

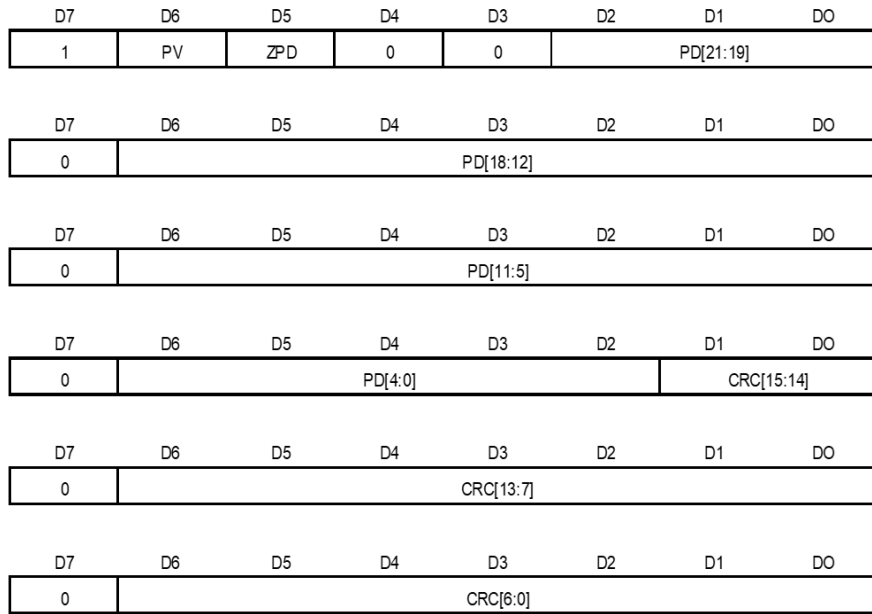

Note: D7[1] is transmitted first.

ASI1 / ASI2 Protocol Data Definition		
Symbol	Definition	Description
PV	Position Valid Flag	Set to 1 when position data valid, otherwise 0.
ZPD	Zero Position Default Flag	Set to 1 when the Zero Point is at Factory Default, otherwise 0.
PD[21:0]	IncOder Position Data	If resolution of device is <22 bits, then the MSBs of this field are set to 0. When PV is 0, PD[21:0] value is not defined.



CRC[15:0]	Cyclic Redundancy Check CRC-16	<p>To verify transmission, calculate the CRC of all 48 bits of the message but with CRC[15:0] set to 0. The resulting 16 bit CRC result should be the same as the received CRC[15:0].</p> <p>Use the following CRC-16 parameters:</p> <ul style="list-style-type: none"> • Polynomial 0x8005 • Initial Data 0x0000 • MSB first (not reversed) • No final XOR calculation.
-----------	-----------------------------------	---

8.4 Serial Peripheral Interface

This section describes the communications interface for IncOders with SPI1 (Serial Peripheral Interface) serial protocols. SPI is a widely used serial interface between micro processors/controllers and peripherals. SPI uses a clock sequence from a master to control the transmission of data from the IncOder. IncOders with SPI data interface conform to the RS422 hardware specification.

SPI Clock Polarity is defined so that the CLOCK idle state is HIGH and the Clock Phase is defined so that the data is captured on the falling edge of CLOCK, and the data is propagated on the rising edge of CLOCK. This is commonly depicted as CPOL=1, CPHA=0 (also depicted as UCCKPL=1, UCCKPH=1).

For SPI communication interface, the acceptable clock frequency is 100kHz to 5MHz.

8.4.1 Serial Peripheral Interface (SPI) - Product Option SPI1

The SPI1 IncOder protocol specifies that each data frame consists of 6 bytes of data (each of 8 bits, 48 bits in total) containing the position, status flags and CRC.

SPI1 Protocol Data Definition			
Bit	Symbol	Definition	Description
D47-D33	SBZ	Set Bit to Zero	These bits will always be Zero.
D32	ZPD	Zero Position Default Flag	Set to 1 when the Zero Point is at Factory Default, otherwise 0.



SPI1 Protocol Data Definition			
D31	PV	Position Valid Flag	Set to 1 when the position data is valid, otherwise 0.
D30	PS	Position Synchronized Flag	Set to 1 when the position measurement was triggered by a previous SPI Frame. Set to 0 when the position measurement was triggered by a Measurement Time-out (see SPI Timing Information, Case 1). Use this flag to ensure that the IncOder has synchronised position measurements to the SPI Frames.
D29-D8	PD[21:0]	Binary Position Data	If resolution of device is less than 22 bits, then the most significant bits of this field are set to 0. The LSB of this field is in D0. When PV is 0, PD[21:0] value is not defined.
D7	SD	Stale Data Flag	Set to 1 when the position data has been transmitted at least once before. Set to 0 when the position data has not been transmitted before. Use this flag to detect when a new measurement has been completed (see SPI Timing Information, Case 2).
D6-D0	CRC[6:0]	Cyclic Redundancy Check	<p>To verify transmission, calculate the CRC of D7-D32. The CRC is calculated using a 32 bit word (or 4 bytes) with D7 shifted in to the Least Significant Bit and the 6 Most Significant Bits set to '0' as required.</p> <p>Use the following CRC-16 parameters:</p> <ul style="list-style-type: none"> • Polynomial 0x5B • Initial Data 0x0000 • MSB first (not reversed) • No final XOR calculation.



8.4.2 SPI1 Timing Information

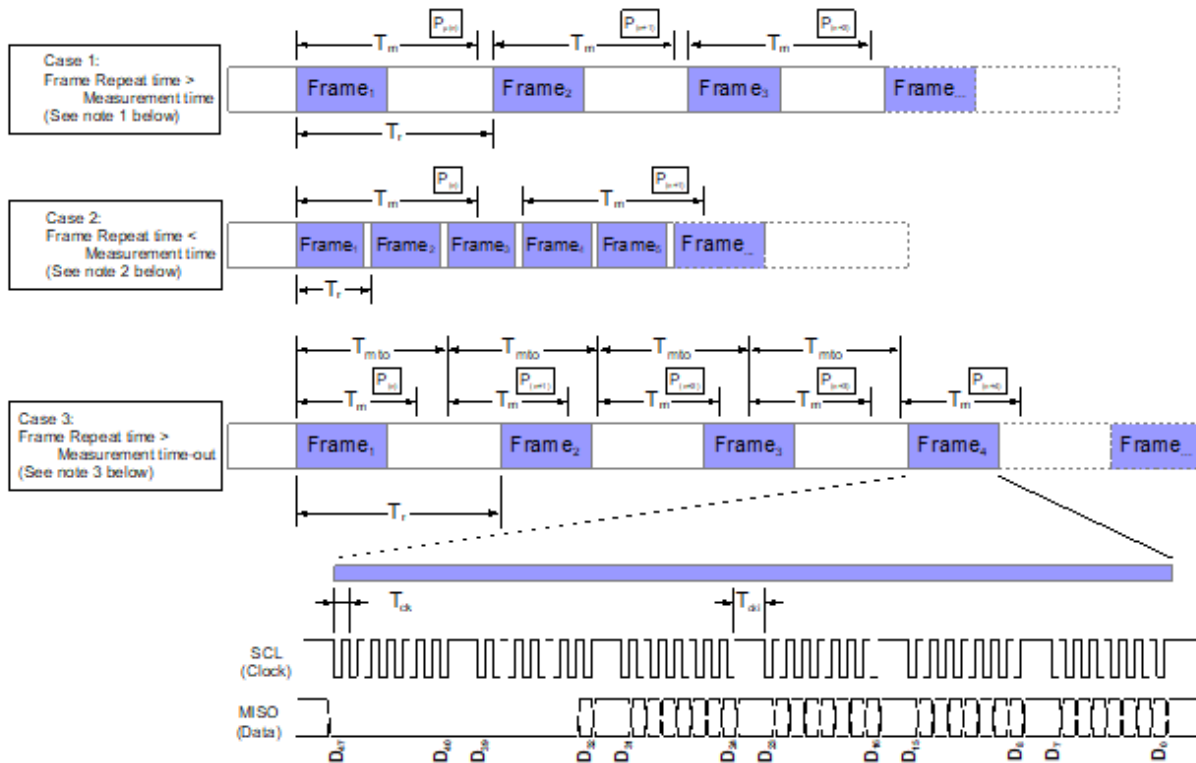

4 SPI1 Timing Information

Timings determined by Controller (SPI Master):		
T_{ck}	Clock Period	$1/T = 100\text{kHz to } 5\text{MHz}$
T_{cki}	Clock Idle Period	Time between bytes during which CLOCK is idle. T_{cki} should be $< T_{ckiMAX} = 10\mu\text{s}$.
T_r	Frame Repetition Rate	



Timings determined by the IncOder (SPI Slave):		
T_m	Position Measurement Time	The time from the start of a position measurement to when the position and status is ready for transmission. $90\mu s \leq T_m \leq 95\mu s$
T_{mto}	Position Measurement Time-out	The time after a position measurement has been triggered that the IncOder will automatically trigger a new measurement. $135\mu s \leq T_{mto} \leq 145\mu s$.

Notes:

1. The IncOder will always attempt to trigger a new position measurement when a new SPI frame is started by the host. This will always be the case when T_r is greater than T_m and less than T_{mto} .
2. If a position measurement has already been triggered when a new SPI frame is started by the host, then a new position measurement will not be re-triggered. This may be the case when T_r is less than T_m .
3. If the Host does not start a new SPI frame within time T_{mto} from the previous frame (the case when T_r is greater than T_{mto}), then the IncOder will automatically trigger a new position measurement.
4. In all cases, the IncOder will transmit the most recently completed measured position and status (see table below).
5. When CLOCK is idle for at least T_{ckimax} , then the IncOder SPI interface will reset. The first falling edge on CLOCK after T_{ckimax} will start the transmission of a new frame. This can be useful if the SPI host and slave (IncOder) lose Frame/Byte synchronisation (detected by invalid CRC).

Frame Number	Position transmitted (Case 1)	Position transmitted (Case 2)	Position transmitted (Case 3)
Frame 1	$P_{(n-1)}$	$P_{(n-1)}$	$P_{(n-1)}$
Frame 2	$P_{(n)}$	$P_{(n-1)}$	$P_{(n)}$



Frame Number	Position transmitted (Case 1)	Position transmitted (Case 2)	Position transmitted (Case 3)
Frame 3	$P_{(n+1)}$	$P_{(n-1)}$	$P_{(n+1)}$
Frame 4		$P_{(n)}$	$P_{(n+3)}$
Frame 5		$P_{(n)}$	



9 How to Order

9.1 IncOder CORE Part Numbers

Note: IncOder is supplied as a rotor and stator pair. Mounting screws and dowels are not included.



CORE - 1 - 44 - 171001 - BIS3 - PR1

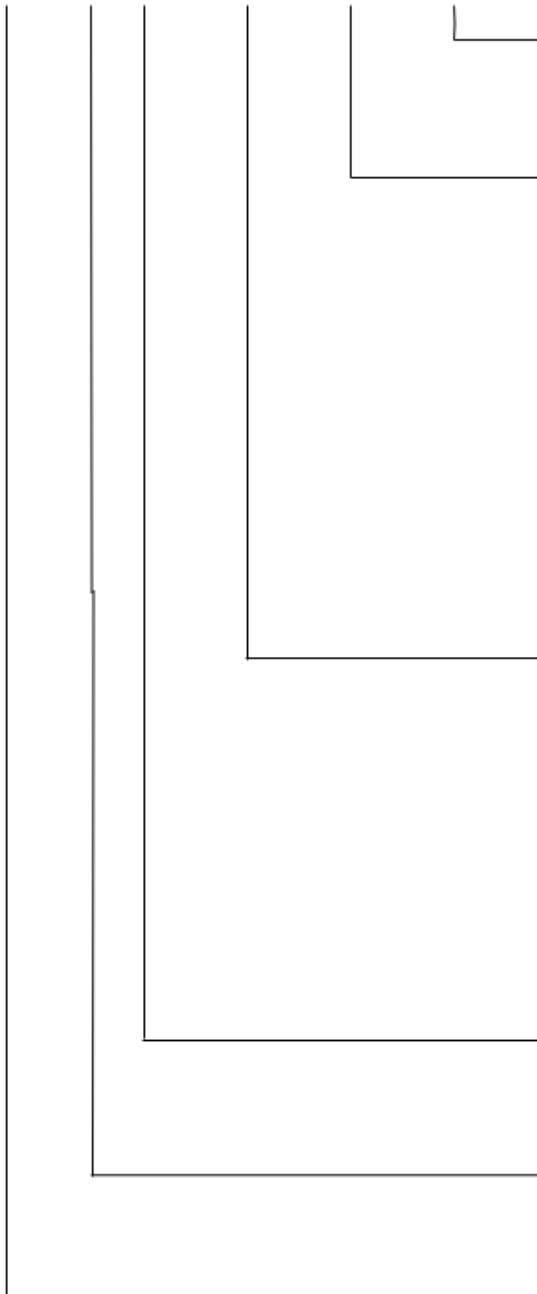

Connection Type

PR1 = Radial Connector Type 1
 PR2 = Radial Connector Type 2
 PA1 = Axial Connector Type 1

Protocol

BIS3 = BiSS-C (unidirectional)
 SPI1 = SPI Type 1
 SSI1 = SSI Type 1
 SSI2 = SSI Type 2
 SSI3 = SSI Type 3⁽¹⁾
 SSI4 = SSI Type 4⁽¹⁾
 SSI5 = SSI Type 5⁽¹⁾
 SSI6 = SSI Type 6
 SSI7 = SSI Type 7
 SSI8 = SSI Type 8⁽¹⁾
 SSI9 = SSI Type 9⁽¹⁾
 ASI1 = Async serial interface 1
 ASI2 = Async serial interface 2

Resolution

201001 = 20 bits⁽²⁾
 191001 = 19 bits⁽²⁾
 181001 = 18 bits⁽²⁾
 171001 = 17 bits
 161001 = 16 bits
 151001 = 15 bits
 141001 = 14 bits
 131001 = 13 bits
 121001 = 12 bits
 111001 = 11 bits
 101001 = 10 bits

Outer Diameter

44 = 44mm Stator OD
 70 = 70mm Stator OD

Mechanical Mounting Format

1 = External Screw Mount Rotor, External Screw Mount Stator⁽³⁾
 3 = Internal Screw Mount Rotor, External Screw Mount Stator⁽⁴⁾

Inductive Encoder Series

CORE = IncOder CORE

Notes



1. For SSI protocol options, maximum resolution limited communications protocol type - See SSI Protocol Options for details.
 2. Maximum resolution available for CORE-x-44 is 17 bits.
 3. Mechanical Mounting Format Option 1 only available for CORE-x-44 size.
 4. Mechanical Mounting Format Option 3 only available for CORE-x-70 size.
-



10 Cable Information

10.1 Cable Part Number

Mating connector and tinned wires on other end.

CORE - CAB1 - 0.25

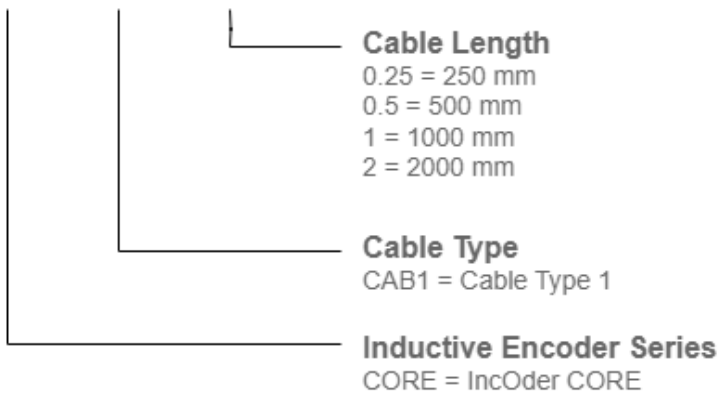

10.2 Cable Drawing

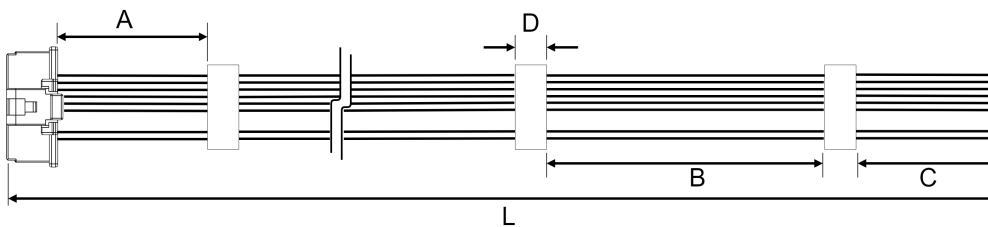

Symbol	Description
L	Total Cable Length (+/- 5 %)
A	Rear-of-connector to edge-of-sleeve: 35 - 40 mm



Symbol	Description
B	Sleeves spaced every 100 - 150 mm (as required)
C	Edge-of-sleeve to wire-ends: 35 - 40 mm
D	Sleeve Width: 20 mm

10.3 Cable Wire Assignment

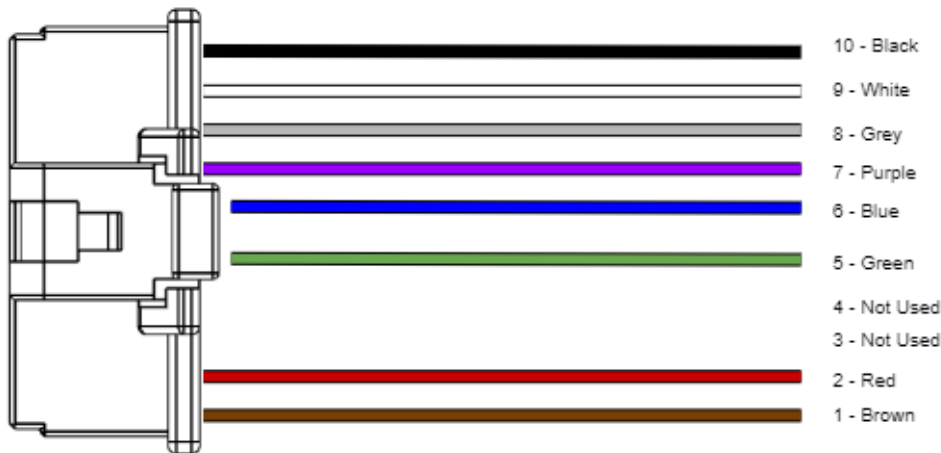

IncOder CORE Cable Connector			
Molex 10-way PicoClasp Connector			
Pin	Colour	Signal	Function
1	Brown	Zero Set	Optional Zero Set function. To use, connect to electrical ground (<0.5V) for >3 seconds at power up but left unconnected (i.e. open circuit) during operation.



2	Red	Zero Reset	Optional Zero Reset function. To use, connect to electrical ground (<0.5V) for >3 seconds at power up but left unconnected (i.e. open circuit) during operation.
3		Reserved	Reserved for future use.
4		Reserved	Reserved for future use.
5	Green	DATA A	Absolute Encoder Output (Data A / Data +)
6	Blue	CLOCK A	Clock Input (Clock A / Clock +)
7	Purple	DATA B	Absolute Encoder Output (Data B / Data -)
8	Grey	CLOCK B	Clock Input (Clock B / Clock -)
9	White	0V	Digital signal ground.
10	Black	V _{supply}	Supply 4.5-5.5V, 8-12V, <100mA



11 Warranty / Remedy

Celera Motion warrants goods of its manufacture as being free of defective materials and faulty workmanship for 1 year from date of purchase. Celera Motion standard product warranty applies unless agreed otherwise by Celera Motion in writing. Please refer to Celera Motion or local representative for warranty details. If warranted goods are returned to Celera Motion during the warranty period then Celera Motion will repair or replace, at its option, without charge those items that it finds defective. The foregoing is the buyer's sole remedy and is in lieu of all other warranties, expressed or implied, including those of merchantability and fitness for a particular purpose. In no event shall Celera Motion be liable for consequential, special or indirect damages.

While Celera Motion provides application assistance personally, through our literature, web-site and partners, it is the customer's responsibility to determine the suitability of the product in the application.

Specifications may change without notice. Quoted data is derived from test, analysis or design similarity. The information provided by Celera Motion in this Product Guide is believed to be accurate and reliable as of this printing, however, Celera Motion assumes no responsibility for its use.

WARNING. PERSONAL INJURY.

Do not use these products as safety or emergency stop devices or in any application where failure of the product could result in personal injury. Failure to comply to these instructions could result in death or serious injury.

WARNING. PERSONAL INJURY.

Do not use these products in any application where there is the potential for combustion or explosion with flammable gases, dust or liquids. Failure to comply to these instructions could result in death or serious injury.