

IKS11 Incremental Magnetic Sensing Head

With the compact incremental magnetic sensing head IKS11, BOGEN offers superb performance in a small form factor. If space is decisive IKS11 is an excellent choice. IKS11 is the preferred choice for automation, instrumentation and motion control applications. In combination with BOGEN precision scales, measurement solutions for almost every application can be custom-tailored.

compact
size

rotary and
linear
applications

scales with or
without
index

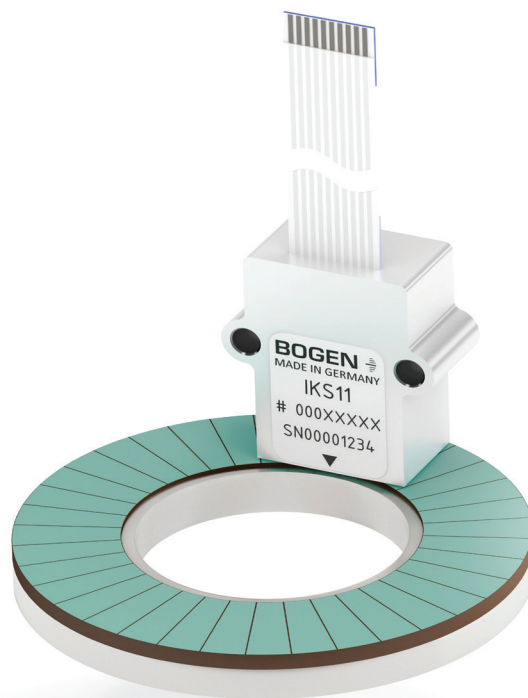

Features and Benefits

- all important operating parameters can be reconfigured by the user at any time
- LEDs indicating input signal quality, error and configuration mode
- extra small size for implementation in confined spaces
- wide range of resolution options available
- no wear due to non-contact operation

Features

resolution	0.020 to 500µm, depending on pole pitch and interpolation
energy consumption (without load)	tbc
operating temperature	- 40 to + 125 °C
storage temperature	- 40 to + 150 °C
adjustable parameters	resolution, maximum output frequency, signal conditioning, filter characteristic, pole pitch, error masks, ABZ or UVM output

Sensing Head Variants

pole pitch (mm)	1, 2, 2.54, 5
reference	periodic reference signal from the pole pitch or from reference marks, requires 2-track magnetic tape with incremental track and reference track
supply voltage	5 V ± 10% (3.3 V on request)
interface (without load)	RS422 (0 to Vcc) push-pull TTL (0 to Vcc)

Output Circuit

RS422

load resistor $Z_0 = 120 \Omega$ at receiving end

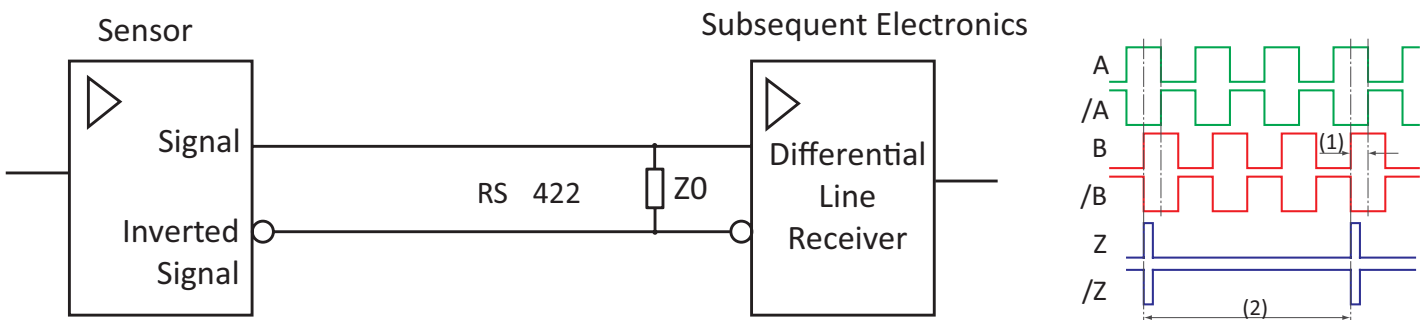

Push-Pull (TTL)

maximum of 50 mA per channel at a supply voltage of 5 V

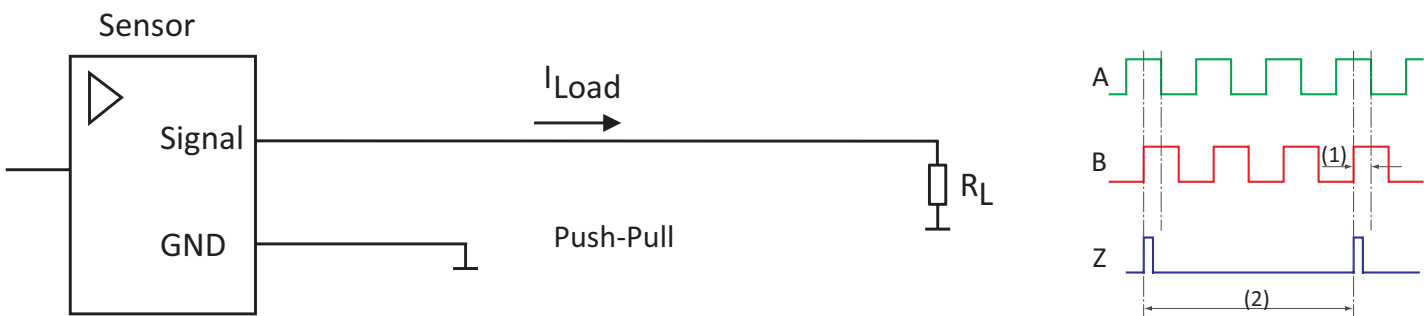

(1) phase shift A and B $90^\circ \pm 10^\circ$ electrical

(2) signal period depending on the reference track pattern

Z length default is 4 counts

Output Signals

signals	A, /A, B, /B, Z, /Z; optional: U, /U, V, /V, W, /W
signal error indicator	red LED shines, if device overheats all outputs are switched off

Installation Tolerances

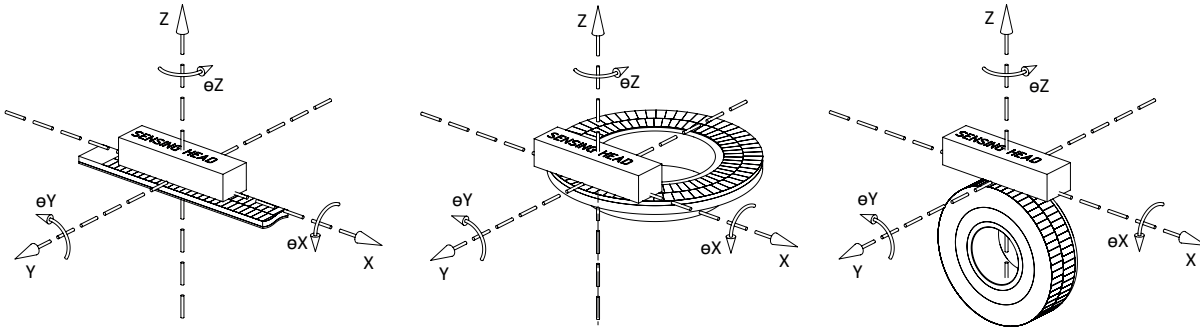

	pole pitch			
	1 mm	2 mm	2.54 mm	5 mm
Z	0.1 to 0.5 mm	0.1 to 1.0 mm	0.1 to 1.25 mm	0.1 to 2.5 mm
Y	0.5 mm	0.5 mm	0.5 mm	0.5 mm
e_Y	1°	1°	1°	1°
e_X	3°	3°	3°	3°
e_Z	3°	3°	3°	3°

Further Selection (Ordering Parameters)

pole pitch P [mm]				resolution R [μm]	resolution Rdpi [dpi]	maximum output frequency per channel F [kHz]					
1	2	2.54 (0.1 in)	5			4000	2500	1000	500	100	50
			x	1250	20.32	100	100	100	100	100	100
	x		x	500	50.8	100	100	100	100	100	90
x	x		x	200	127	100	100	100	100	72	36
x	x		x	100	254	100	100	100	100	36	18
	x			80	317.5	100	100	100	100	28.8	14.4
x	x		x	62.5	406.4	100	100	100	100	22.5	11.25
x	x		x	50	508	100	100	100	90	18	9
x	x		x	40	635	100	100	100	72	14.4	7.2
x	x		x	25	1016	100	100	90	45	9	4.5
x	x	x	x	20	1270	100	100	72	36	7.2	3.6
x	x	x	x	12.5	2032	100	100	45	22.5	4.5	2.25
x	x	x	x	10	2540	100	90	36	18	3.6	1.8
x	x	x	x	5	5080	72	45	18	9	1.8	0.9
x	x	x	x	4	6350	57.6	36	14.4	7.2	1.44	0.72
x	x	x	x	2.5	10160	36	22.5	9	4.5	0.9	0.45
x	x	x	x	2	12700	28.8	18	7.2	3.6	0.72	0.36
x	x	x	x	1	25400	14.4	9	3.6	1.8	0.36	0.18
x	x	x	x	0.5	50800	7.2	4.5	1.8	0.9	0.18	0.09
x	x	x	x	0.25	101600	3.6	2.25	0.9	0.45	0.09	0.045
x	x	x	x	0.125	203200	1.8	1.125	0.45	0.225	0.045	0.0225
x	x	x		0.05	508000	0.72	0.45	0.18	0.09	0.018	0.009
x	x			0.02	1270000	0.288	0.18	0.072	0.036	0.0072	0.0036

table 1: maximum output frequency and speed as a function of pole pitch and resolution

R	resolution (resolution is post quadrature), $R = P / R_f$	F	highest frequency of an output signal under all conditions
P	pole pitch, available 0.5, 1, 2, 2.54, 5 mm	V_{max}	highest allowed movement speed V_{max} is the smaller value resulting from the formulas (- 10 %): $V_{max1} = 4 * F * R$ and $V_{max2} = P * 50 \text{ kHz}$
R_f	resolution factor (resolution factor available from 4 to 65536 in integer increments of one)	Rdpi	resolution [dpi], $Rdpi = 25400 / R$

Dimensions

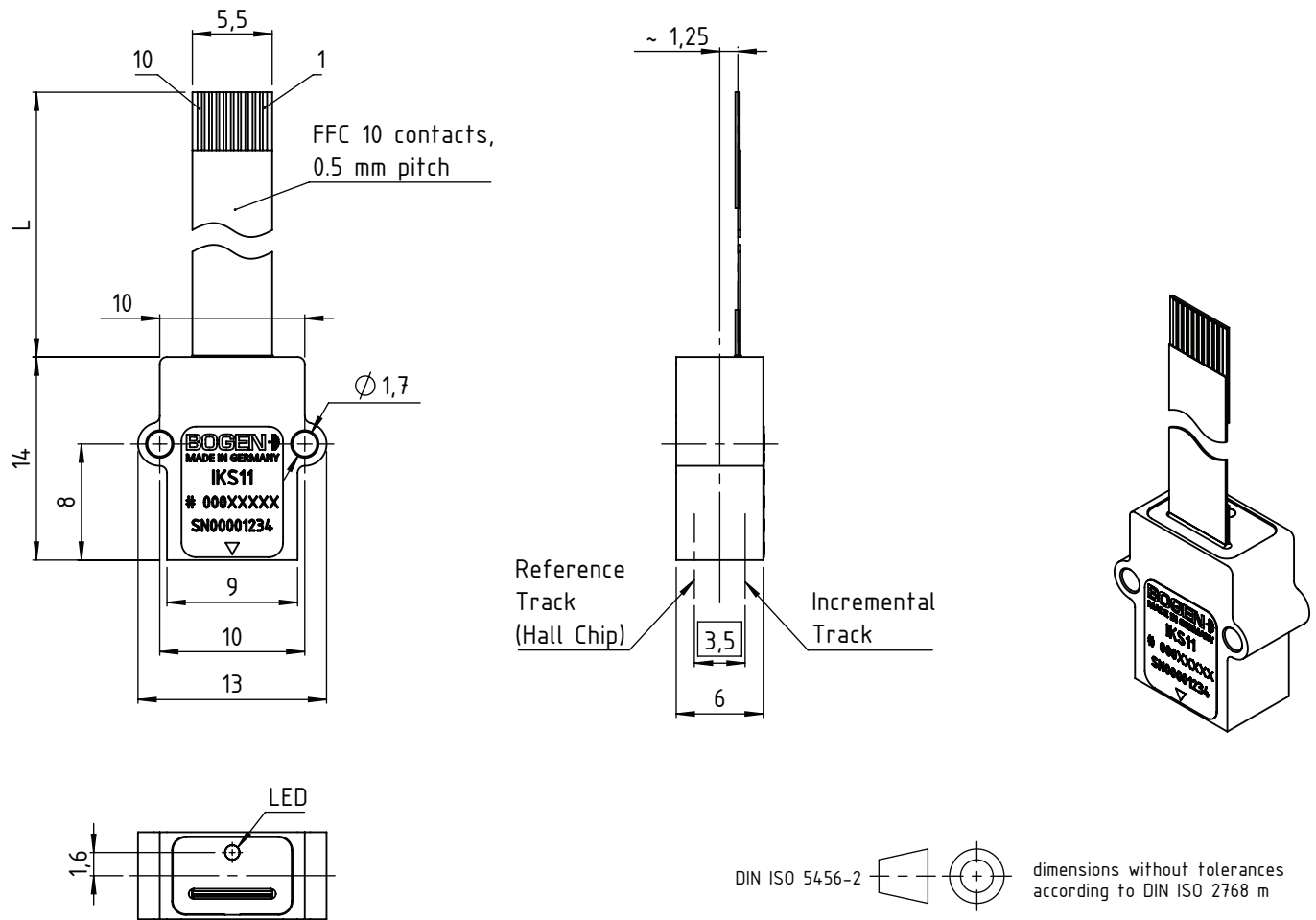

pin no.	1	2	3	4	5	6	7	8	9	10
signal	!PROG	SDO	/Z	Z	/B	B	/A	A	V+	V-

LED Signaling

The RGB-LED of the IKS11 lights blue if the head is in programming mode. It lights red if there is an error. Error types activating the LED can be configured. LED lights green to show an active input signal, the brightness indicates the quality of the input signal.

Programming Mode

The user may change the configuration of the IKS11 by setting it into programming mode. The 5V supply version of the IKS11 is set into programming mode by holding the !PROG input LOW. The 3V supply version overdrives A and /A outputs.

Magnetic Sensing Head Order Code Parameters

IKS11 - Z - P - D - R - F - L

		code	explanation ⁽⁶⁾
Z	reference signal ⁽⁷⁾	Z1. ...	periodic reference signal from the pole pitch, length of reference signal ... counts ⁽⁸⁾
		Z2. ...	from reference marks, requires 2-track magnetic tape with incremental track and reference track, length of index signal 1, 2 or 4 counts ⁽⁸⁾
P	pole pitch [mm]	P1	1 mm
		P2	2 mm
		P2.54	2.54 mm
		P5	5 mm
D	interface	D1	RS422 ABZ
		D2	RS422 UVW
		D3	TTL ABZ
		D4	TTL UVW
R	resolution [µm]	R0.5	0.5 µm resolution, standard for a pole pitch of 1 mm
		R1	1 µm resolution, standard for a pole pitch of 2 mm
		R...	other non-default resolutions, see section "Resolution and Speed" in table 1 on page 3
F	maximum output frequency per channel [kHz]	F1000	output frequency 1000 kHz
		F...	other non-default output frequencies, see section "Resolution and Speed" in table 1 on page 3
L	length	L100	length of FFC
		L300	

⁽⁶⁾ default parameters are bold

⁽⁷⁾ if no index signal is needed, please do not connect pin "Z" an "/Z" on delivered connector

⁽⁸⁾ length of index signal available from 1 to 4

Linear and Rotary Scales

- LMS: linear magnetic scale, from a few millimeters to many meters
- LMSBI: linear magnetic scale bar incremental for high accuracy applications
- RMSI: rotary magnetic scale incremental, in diameters from 10 mm to 1 m
- standard scale width (with reference track): 8 mm and 10 mm; 6 mm on request
- available scale accuracy classes: A3, A10, A20, A40, A100
- available pole pitches: 1 mm, 2 mm, 2.54 mm, 5 mm

LMS Linear Magnetic Scales Order Code Examples

LMS-I1-L1000-W10-A20-K	linear magnetic scale number of tracks: 1 track1: incremental 1 mm pole pitch accuracy class: $\pm 20 \mu\text{m/m}$ total width: 10 mm total height: 1.43 mm total length: 1000 mm usable measuring length: 990 mm without cover tape with adhesive tape with BOGEN standard imprint
LMS-I2-L1000-W10-A20-K	linear magnetic scale number of tracks: 1 track1: Incremental 2 mm pole pitch Accuracy class: $\pm 20 \mu\text{m/m}$ total width: 10 mm total height: 1.43 mm total length: 1000 mm usable measuring length: 990 mm without cover tape with adhesive tape with BOGEN standard imprint

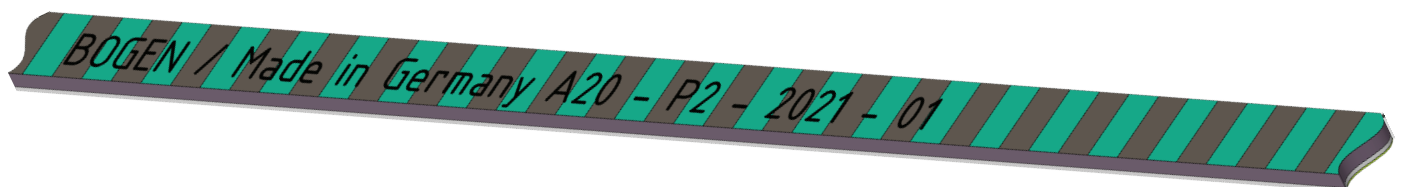

LMS Linear Magnetic Scales Order Code Examples

<p>LMS2-I1-Z-L1000-W10-A20-K</p>	<p>linear magnetic scale number of tracks: 2 track1: Incremental 1 mm pole pitch, 5 mm track width track2: Reference NSN reference every/at XX mm / at center, 5 mm track width accuracy class: $\pm 40 \mu\text{m}/\text{m}$ total width: 10 mm total height: 1.43 mm total length: 1000 mm usable measuring length: 990 mm without cover tape with adhesive tape with BOGEN standard imprint</p>
<p>LMS2-I2-Z-L1000-W10-A20-K</p>	<p>linear magnetic scale number of tracks: 2 track1: Incremental 2 mm pole pitch, 5 mm track width track2: Reference NSN reference every/at XX mm / at center, 5 mm track width accuracy class: $\pm 40 \mu\text{m}/\text{m}$ total width: 10 mm total height: 1.43 mm total length: 1000 mm usable measuring length: 990 mm without cover tape with adhesive tape with BOGEN standard imprint</p>

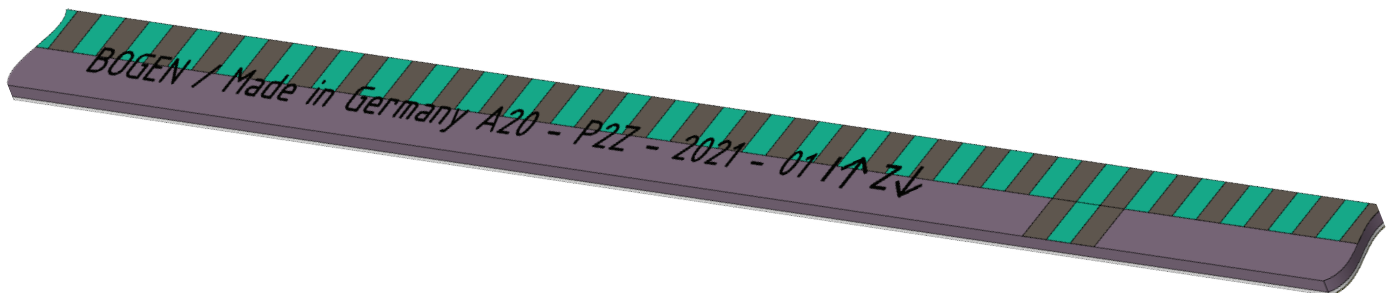

BOGEN Magnetics GmbH reserves the right to make changes, without notice, in the products, including software, described or contained herein in order to improve design and/or performance. Information in this document is believed to be accurate and reliable. However, BOGEN Magnetics GmbH does not give any representations or warranties, expressed or implied, as to the accuracy or completeness of such information and shall have no liability for the consequences of use of such information. BOGEN Magnetics GmbH takes no responsibility for the content in this document if provided by an information source outside of BOGEN products. In no event shall BOGEN Magnetics GmbH be liable for any indirect, incidental, punitive, special or consequential damages (including but not limited to lost profits, lost savings, business interruption, costs related to the removal or replacement of any products or rework charges) irrespective the legal base the claims are based on, including but not limited to tort (including negligence), warranty, breach of contract, equity or any other legal theory. Notwithstanding any damages that customer might incur for any reason whatsoever, BOGEN product aggregate and cumulative liability towards customer for the products described herein shall be limited in accordance with the General Terms and Conditions of Sale of BOGEN Magnetics GmbH. Nothing in this document may be interpreted or construed as an offer to sell products that is open for acceptance or the grant, conveyance or implication of any license under any copyrights, patents or other industrial or intellectual property rights. Unless otherwise agreed upon in an individual agreement BOGEN products sold are subject to the General Terms and Conditions of Sales as published at www.bogen-magnetics.com